

# DUNLOP DL40

## 2 Post Electro-Hydraulic 4.0 Tonne Lift

### Features

- Electrically operated safety ratchets
- Control box operates all functions
- Symmetric arm configuration
- Automatic arm locks
- Low friction sliding carriage guides
- Two year warranty on control box and pump assembly
- Free set of 90mm & 125mm lifting adaptors (two sets of 4)
- Choice of single or three phase
- Screw adjustable lifting pads
- Supplied with base plate
- CE Approved

### Technical Data

Operation	Electro-hydraulic
Capacity	4000kg
Lifting time	50 seconds
Lowering time	40 seconds
Lifting height	1880mm
Lowest height	110mm
Motor 3 phase	2.2kW x 380/415 volt x 50Hz
Motor 1 phase	2.2kW x 220/240volt x 50Hz
Width external	3370mm (outside)

### Application

- Car and light commercials
- Brake repairs and service
- Suspension replacement
- Transmission repair and replacement
- Tyre shop
- General repair bay

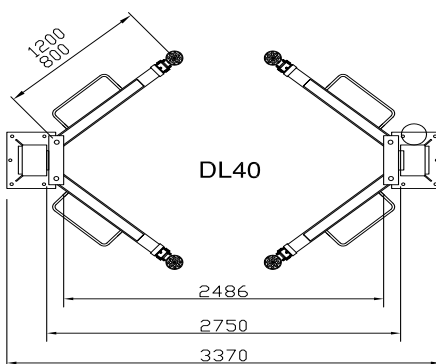
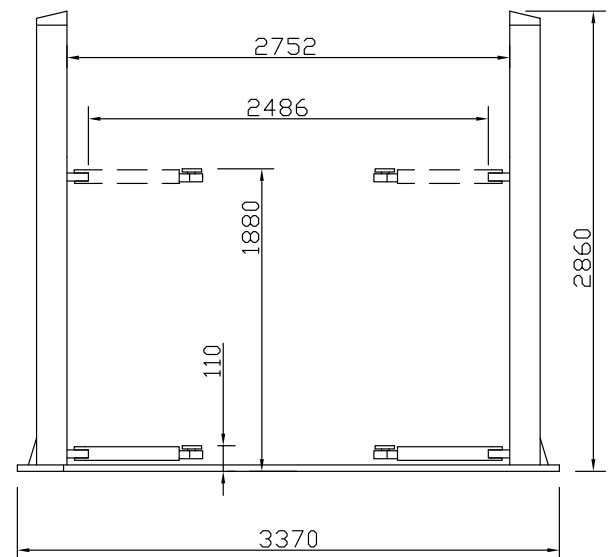

Distributed by: