

DLSRM1 / DLSRM3

Dunlop Scissor Surface Mounted Lifts

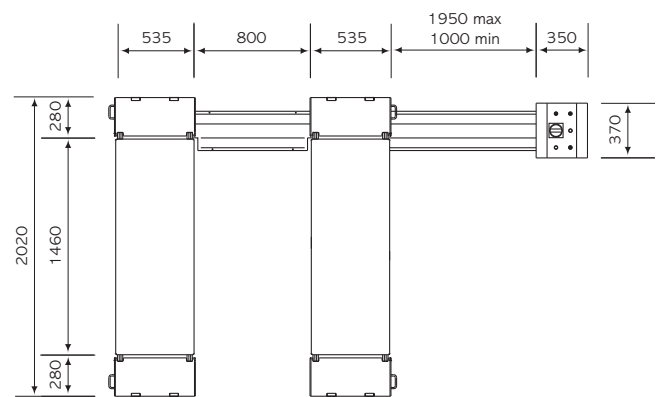

Elevation & plan

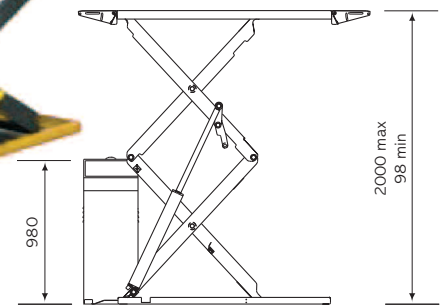

Features

- Extra low profile hydraulic scissors lift
- Easy to handle drive-on and drive-off ramps
- Hydraulically synchronized platforms
- Overload and safety valve in case of sudden loss of pressure
- Automatic lowering control
- Dead man controls 24 volt
- Set of 4 rubber pads
- Warning buzzer on last portion of descent

Technical data

Operation	Electro-hydraulic
Capacity	3200 kg
Weight	730 kg
Lifting time	35 seconds
Lowering time	40 seconds
Lifting height	2000 mm
Minimal height	98 mm
Motor	3kW - 3ph. 230-400V/50Hz

Optional accessories

- Two metre hose extension

Application

- Car service bays
- Bodyshops in conjunction with jig and panel repairs
- Brake repairs and service
- Suspension replacement
- Transmission repair and replacement
- Tyre shop (all 4 wheels can be removed)
- General repair bay

Elevation & plan for reference purposes only, do not scale

Distributed by