

# DUNLOP DMC32M

## 8.0 tonne mobile column lift

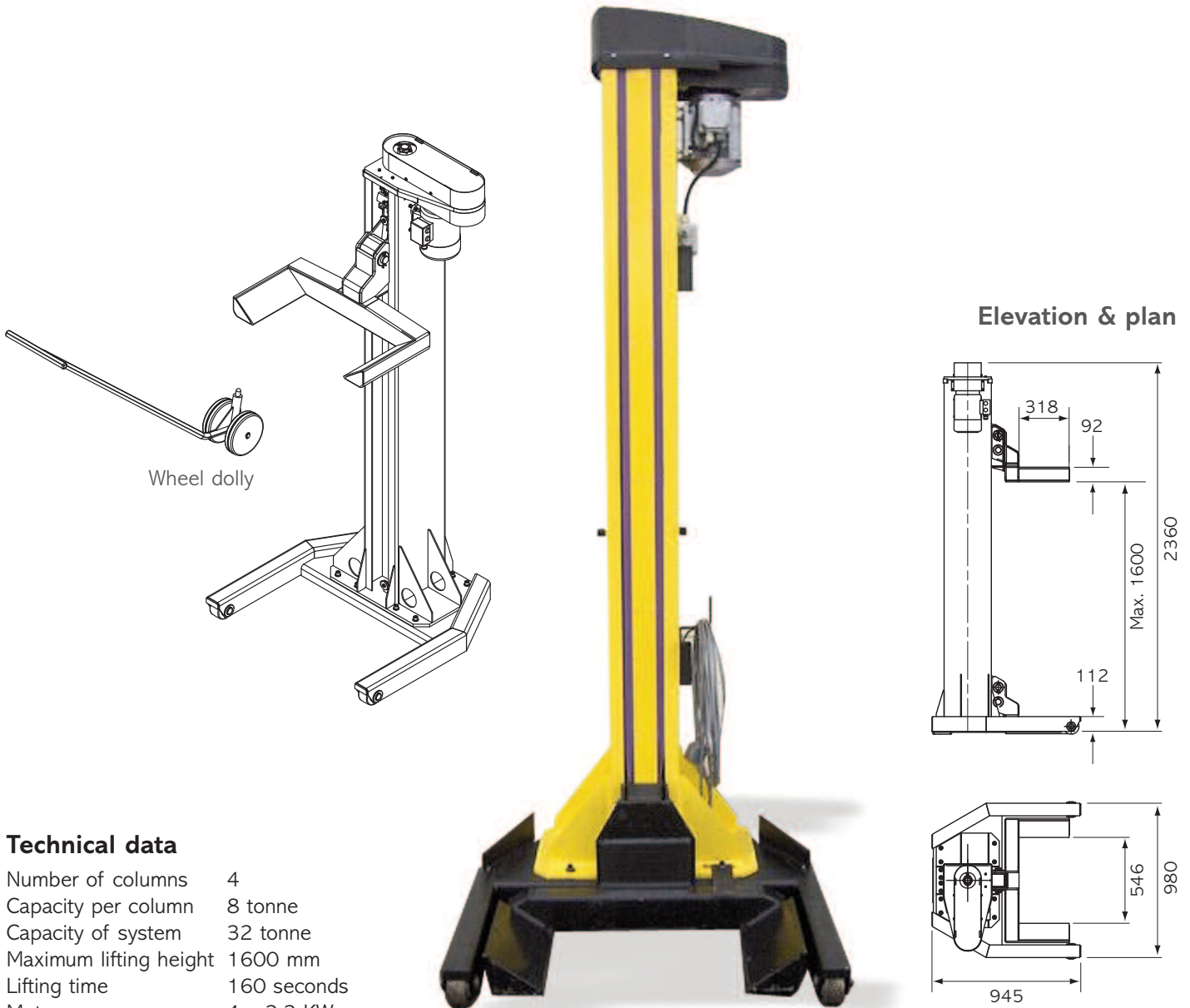

### Technical data

Number of columns	4
Capacity per column	8 tonne
Capacity of system	32 tonne
Maximum lifting height	1600 mm
Lifting time	160 seconds
Motor power	4 x 2,2 KW
Power requirement	400 V/3 Ph/50 Hz
Weight per column	550 kg
Wheel fork size	870 mm – 1080 mm
Wheel fork length	320 mm

### Standard accessories

Wheel dolly

### Optional accessories

Small Wheel Adaptors.  
Trailer Beam.

Elevation & plan for reference purposes only. Do not scale.

Distributed by

DMC32M - 16:03:09