

DUNLOP DL30

2 Post Electro-Mechanical 3.0 Tonne Lift



Features

- Safety nut system
- Auto arm locks
- Toe guards
- Deadman controls 24 volt
- Automatic lubrication
- CE approved

Technical data

Operation	Electro-mechanical
Capacity	3000 kg
Weight	620 kg
Lifting time	55 seconds
Lifting height	1890 mm
Motor	3ph. 230-400V
Width external	3170 mm
Width internal	2460 mm
Pad height	90-190 mm

Application

- Car service bays
- Bodyshops in conjunction with jig and panel repairs
- Brake repairs and service
- Suspension replacement
- Transmission repair and replacement
- Tyre shop
- General repair bay

Elevation

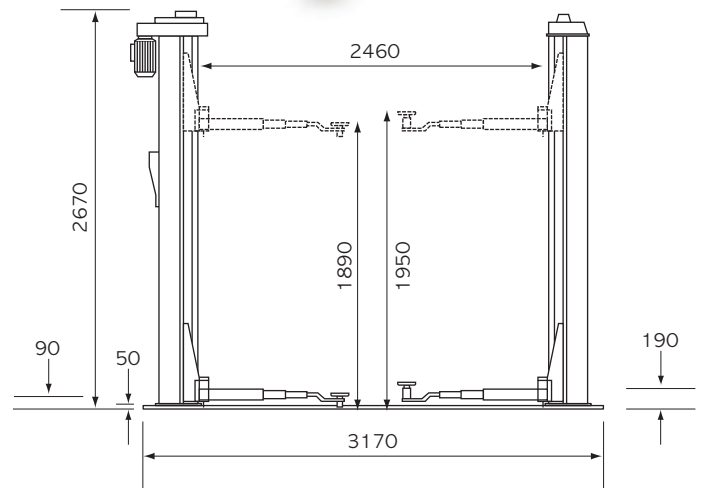

Elevation for reference purposes only, do not scale

Distributed by

DL30 - 16:03:09